

## Feeder system for uncoiling line

Automatic selector of the coil, feeds different width and thickness of metal coils from several decoilers

- Width capacity: 1,000, 1,250, and 1,500 mm
- Automatic material infeed system
- Coil selection at the control console

## Extensible roller table : TRX

Useful for roll-forming and trays mechanical bender for standing seam and cleat forming. Adjustable in height to provide perfect flatness on the way out of the machine, they are fixable with each other to work longer lengths

Features	TRX
Height (mm)	70 to 940
Length S235JR (mm)	420 x 1 300
Width (mm)	500
Coils diameter (mm)	42
Number of coils	9
Maxi load (kg)	150
Weight (kg)	42

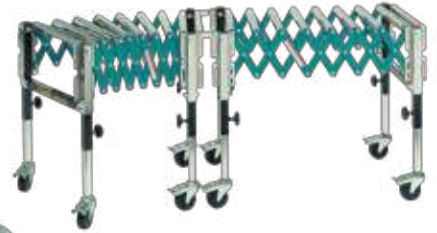

## Decoiler : DVD1000

- Two-wheeled decoiler for handling and uncoiling up to 200 kg coils

## DVS1000

- Equipped with 4 swivelling wheels with a brake
- Mandrel expansion from 285 to 540 mm
- Max external diameter of the coil 1000 mm
- Manual brake



Model DVD1000

## SDS50

- Max external diameter of the coil 1200 mm
- Uncoiler on 2 supports
- Manual brake
- To be used in fixed position or on rolls and rails on the floor (option)
- Mandrel expansion from 390 to 610 mm



Model DVS1000



Model SDS50

	DVD 1000	DVS 1000	SDS50-100S	SDS50-125S	SDS50-150S
Width (mm)	500	1 000	1 000	1 250	1 500
Maxi charge (kg)	200	1 200	5 000	5 000	3 000

## Decoiler : DVS1000E

- The modular decoiler DVS1000E allows optimum storage and handling.
- Mandrel expansion from 285 to 540 mm
- Up to 850 mm maximum external diameter



Model DVS1000E

● **Single side mandrel DPF**

- Useful length from 300 to 1500 mm
- Capacity from 500 kg to 15 tonnes
- Expanding mandrel from 470 to 630 mm



DPF101 M



DPF301M



Features							
Useful width (mm)		300	600	800	1000	1250	1500
Maxi charge (kg)	Manual	500	1 000	4 000	1 000	4 000	4 000
	Motorized	1 000	6 000	6 000	8 000	15 000	15 000
mandrel rotation	Manual (maxi 4 t)	✓	✓	✓	✓		
	Electric	✓	✓	✓	✓	✓	✓
Expanding mandrel*	M	✓	✓	✓	✓		
	HM	✓	✓	✓	✓		
	HE			✓	✓	✓	✓
Options	Presser arm	✓	✓	✓	✓	✓	✓
	Coil loading carriage			✓	✓	✓	✓

M: Manual ; HM: hydraulic with manual control ; HE: hydraulic with electric control



DPF600 + HE system



DPF300 + HE system + presser arm

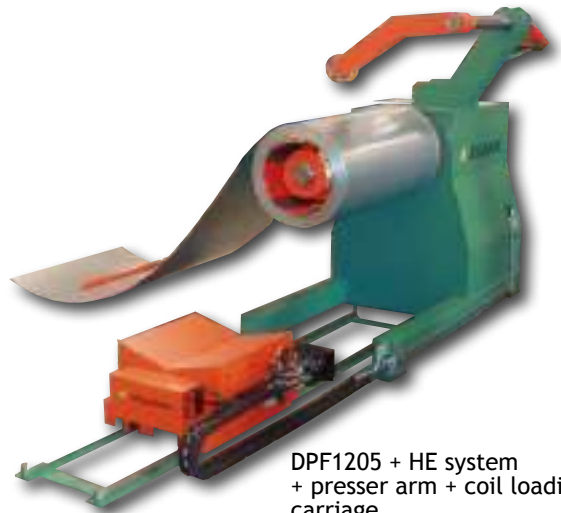

DPF1205 + HE system + presser arm + coil loading carriage

● **Coil loading carriage**

- Capacity from 5 to 15 tons
- Hydraulic lifting system
- Vertical travel 400 mm
- Hydraulic horizontal translation system 2 m

● **Kink control**

For regulation of metal pressure to avoid kinking of metal during construction

● **Presser arm**

Holds the coil in place: pneumatic or hydraulic operation,  
Max reel diameter: 2,0 m

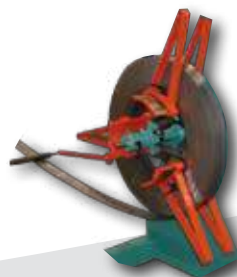

Kink control



Coil loading carriage

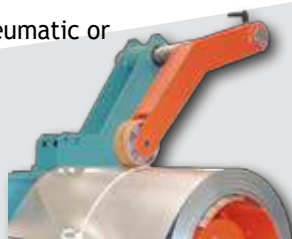

Presser arm